



**LED**

# 40W 1 MODULE STREETLIGHT LIGHT SERIES

BMP-STREETM-40-150V-10

- White
- Grey
- Black



## SPECIFICATIONS

|                          |                                  |
|--------------------------|----------------------------------|
| System Power             | 40w                              |
| Milliamps                | 800Ma                            |
| LED type                 | LUMILEDS 5050 28Pcs each Module  |
| Lamp Body Material       | Aluminium Alloy                  |
| Colour Temperature       | 5700k,4000k,3000k                |
| Luminous Flux            | 7,170lumens                      |
| Luminous Efficacy        | 178lm/w                          |
| CRI                      | Ra70 (Ra80/90 optional)          |
| Beam Angle               | TYPE I, II , III , IV , V        |
| Light Distribution Curve | Various                          |
| Rated Lifespan           | >100,000 hours Modules           |
| IP Rating                | IP66 Housing , IP68 Modules      |
| Impact rating            | IK08                             |
| Driver Type              | Moso Flicker Free X6-075MO62     |
| Operating Temperature    | -40°C ~ 50°C                     |
| Dimmable                 | PWM Dimming                      |
| Test Reports             | TM21,LM80,L70                    |
| Lamp Dimension           | 577 x 330 x 155 mm               |
| Net Weight               | 7.2kg                            |
| Warranty                 | 5 years driver, 10 years Modules |
| Certification            | JAS/ANZ TUV                      |

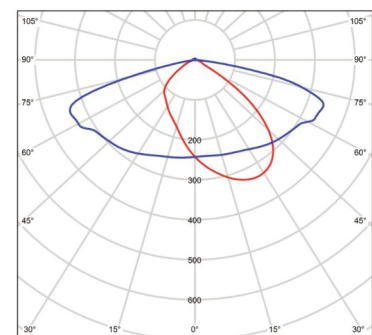
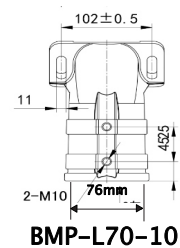
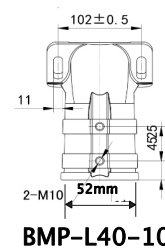
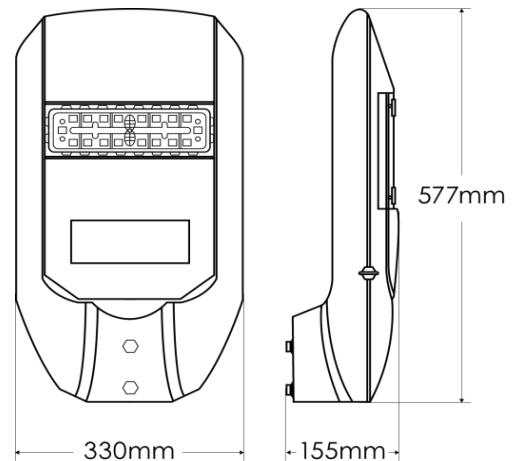

Type II (Most Common)  
BMP-STREET2-40-150V-10

**See next page for other distributions**



# 40W 1 MODULE STREETLIGHT LIGHT SERIES

BMP-STREETM-40-150V-10

For accessories, contact BMP LED via [www.bmpled.com.au/contact](http://www.bmpled.com.au/contact)

## ACCESSORIES

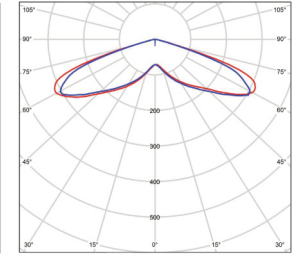
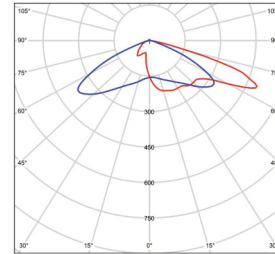
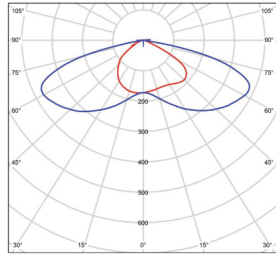
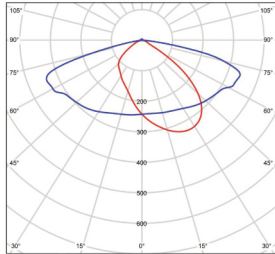
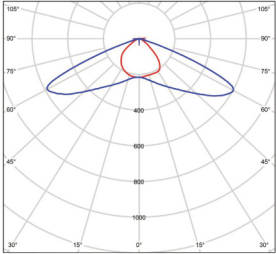

Type I  
BMP-STREET1-40-150V-10

Type II  
BMP-STREET2-40-150V-10  
(Most Common)

Type III  
BMP-STREET3-40-150V-10

Type IV  
BMP-STREET4-40-150V-10

Type V  
BMP-STREET5-40-150V-10

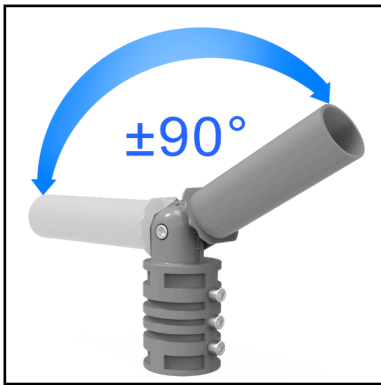

Streetlight pole Adaptor  
Black/Grey/White Options  
BMP-STREETAD-10(B/G/W)



3 Pin Phot Cell  
Pe Cell and base  
BMP-STREETCELL3-10



Driver Extension Cable  
2.0m,5.0m,12.0 lengths  
BMP-DEC/2/5/12-10

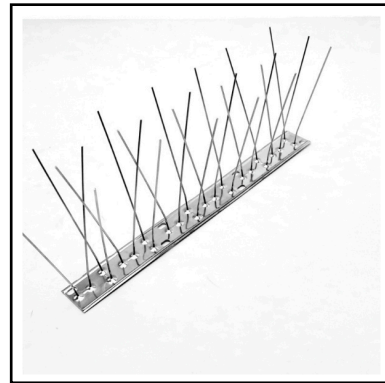

Birdspikes  
0.33m  
BMP-BIRDSPIKES-10